



Hozhoni Art Program Development of an Assistive Workstation

Final Report

Logan Bacher

Adam Barad

Brittnee Barrett

Maggie Collins

Jeannette Nelson

2015-16

Project Sponsor: Hozhoni Foundation

Faculty Advisor: Dr. Sara Oman

Sponsor: W.L. Gore and Associates

Instructor: Dr. Sara Oman

DISCLAIMER

This report was prepared by students as part of a university course requirement. While considerable effort has been put into the project, it is not the work of licensed engineers and has not undergone the extensive verification that is common in the profession. The information, data, conclusions, and content of this report should not be relied on or utilized without thorough, independent testing and verification. University faculty members may have been associated with this project as advisors, sponsors, or course instructors, but as such they are not responsible for the accuracy of results or conclusions.

Table of Contents

DISCLAIMER	1
1 Background.....	4
1.1 Introduction	4
1.2 Original System.....	4
1.2.1 Original System Structure	4
1.2.2 Original System Operation.....	4
1.2.3 Original System Performance	4
1.2.4 Original System Deficiencies	5
2 Requirements	5
2.1 Customer Requirements.....	5
2.2 Engineering Requirements.....	6
2.3 Testing Procedures	7
2.4 Design Links.....	7
2.5 House of Quality	8
3 Existing Designs	9
3.1 Design Research	9
3.2 System Level	10
3.2.1 Populas Wheel Chair Accessible Desk.....	10
3.2.2 ErgoRest Arm Support.....	10
3.2.3 Ergo Q330 Notebook Stand	10
3.2.4 Da Vinci Multi Media Easel.....	10
3.2.5 Digital Wheel Art.....	10
3.2.6 Mabef Workstation Easel.....	11
4 Designs Considered.....	11
4.1 Folding Easel.....	11
4.2 Round-About Easel	11
4.3 Sawhorse Easel	11
4.4 Full Moon Easel.....	11
4.5 Skeleton Easel	11
5 Designs Selected.....	12
5.1 Rationale for Design Selected.....	12
5.2 Design Description	13
5.2.1 Table Top (1)	14
5.2.2 Leg Assembly (2).....	14
5.2.3 Easel Backboard (3).....	14
5.2.4 Metal Rod Support (4)	14
5.2.5 Leg Bracket.....	15
5.2.6 Saw Rod (5).....	15
5.2.7 Processes Diagrams	15
Figure 10: Elevating Process.....	16
6 Implementation	16

Appendix A	19
Appendix B	20
Appendix C.....	23

1 Background

1.1 Introduction

The primary goal of the Art Team's senior design project is the successful design, build, and implementation of an assistive working station for the comfortable holding of Hozhoni clients' work and supplies during creation. The Hozhoni Foundation is a local Flagstaff organization dedicated to the support of individuals with developmental disabilities [1]. While the foundation provides a number of services to its clients, one of the largest programs is the Hozhoni Artists Program—a nonprofit studio for Hozhoni clients where they can spend time on self-expression and creativity [2].

The day program is renowned for aiding in the self-expression of the artists; applauded for its ability to foster growth, communication, and awareness in a guided atmosphere [1]. The clients are encouraged to experiment with a number of different mediums with help from fellow artists and staff. One of the largest challenges for the program however is in creating a comfortable working environment for those clients with special mental and physical needs [1]. Due to the unique disabilities faced by program individuals finding a comfortable and ergonomic method of painting or drawing has proven difficult to accomplish. It is therefore the goal of this project to create a tool for the program's use that provides physical support during work for the Hozhoni clients.

Upon building of a successful workstation the clients will have a place where they can work comfortably for an extended period of time with convenient supplies and aid. Ideally this will aid in increasing productivity and reduce long-term physical harm.

1.2 Original System

The following subsections detail the original system structure, functions, and deficiencies. Many of the characteristics described are instrumental in the formation of the customer and engineering requirements discussed in subsequent sections.

1.2.1 Original System Structure

The Hozhoni Foundation Art Program provides aid and support to individuals with disabilities—allowing for their creative expression in a guided environment. The art program frequently supports 15-30 individuals in a multi-room studio environment. There are three main rooms where artists are supplied with the tools they require for painting, drawing, pottery, printmaking, metal work, sculpture, textiles, and carving [1]. Tools and equipment are stored in small, locked storage rooms when not in use.

Currently almost all artwork is done on tables. The two easels the foundation possesses are a simple three-point easel and a wooden support, which can be placed on tables or used to display art upon completion. These two easels are insufficient for use in the program and are discussed further in the Original System Deficiency subsection below. Art supplies are abundant and the knowledgeable staff offers as much support as necessary while allowing the client's own creativity.

1.2.2 Original System Operation

The creation of this assistive workstation must not dramatically change the current operation of the Art Program as specified in the Customer Requirements section. The current staff is primarily women who aid the day program during the eight-hour working shifts. The staff must be capable of moving the workstation as well as storing the platform in the limited storage locations. These operational requirements are likewise further discussed in the Customer Requirements section.

1.2.3 Original System Performance

The current art program is renowned for its support of the Hozhoni clients. The disabilities the clients face range in both type and severity from developmental to physical to mental and emotional. The services provided by the Hozhoni Foundation have allowed many of these individuals to experience life and opportunities like anyone else [1]. The art program provides a way for these clients to express their

creativity, uniqueness, and emotion. Unfortunately, many of the clients have suffered from poor posture and joint pain. This could be in part due to the lack of ergonomic and supportive workstation as well as long time spans sitting in the same location. There is also very little support for wheelchair bound clients.

1.2.4 Original System Deficiencies

The primary deficiency in the way the Hozhoni Foundation currently conducts their art program is in the existence of workstations. There are two primary easels:

1. Three point easel: The three-point easel is a small, non-adjustable wooden support with three legs. Currently only one client uses the easel due to the lack of adjustability and inability to accommodate clients bound to wheelchairs. The easel is also flimsy, cannot hold large canvas or paper, and must be supported by other means while drawing.
2. Wooden support: The wooden support is a heavy, non-collapsible wooden structure that allows for the propping of canvas. It is currently only used to display finished work or paintings in progress.

Neither the three-point easel nor the wooden support allow for the holding of art supplies. Current clients are therefore more likely to use tables to draw and many suffer from back pain due to lack of support and poor posture. It is therefore vital for our workstation to provide the necessary support for both sitting and standing clients.

2 Requirements

The team's main goal is to create a system that helps Hozhoni clients in the art program work more comfortably. With that in mind, the team and the Hozhoni Foundation worked together to develop a series of design requirements that the team should consider in the generation on their ideas. The team must design a system that will assist current and future Hozhoni clients with their art and other creative projects. The system must help the clients work more comfortably throughout the day, and provide multiple configuration options to accommodate the client's needs. With these broad design constraints in mind, the team generated a series of customer requirements, which were further clarified with engineering requirements.

2.1 Customer Requirements

Based on the conversations with the Hozhoni Foundation, the team came up with ten customer requirements that could be used to assess the feasibility of the designs. Each of these requirements was weighted with a point value out of 250 total points. The weight represents the importance of each requirement relative to each other, with a higher number of points correlating to a higher importance to the overall project goal. The customer requirements are listed in Table 1 below.

The most important requirement, with a weight of 45 points is that the system has an adjustable configuration. The Hozhoni Foundation has observed a clear increase in focus and productivity in some of their clients when they transition between sitting and standing to do their art. They also have several clients in wheelchairs that find themselves very limited on where in the studio they can work due to the table height and space restrictions. Any system designed should be able to accommodate artists sitting and standing, and also in wheelchairs. Next, and also very important to the client, the system must be durable. The art program is open for client use eight hours a day almost every day of the year. In order to be feasible the system must be able to last at least several years. Because the art program is so large and active, they are looking for a system that can be easily stored out of the way when not in use in order to leave more floor space for client use, and decrease safety hazards.

Furthermore, clients tend to work on their art for hours at a time, so the system that the team creates must be comfortable for daily use for prolonged periods of time. It must also be safe to use, and clients should not require supervision while using it. Most of the Hozhoni workers in the art program are female, and

clients often largely outnumber them. In order for a system to be feasible it must be able to be set up easily by one person, more specifically, a female worker.

The artists at the Hozhoni Foundation use a variety of sizes and types of templates for their art, from canvas, to cardboard, to paper. The customer would like a system that can accommodate the variety of resources at the foundation’s disposal, so it must be able to accommodate different size templates, and also different types of templates. As was mentioned earlier, space in the art studios is fairly limited, so an ideal system should be able to contain the artists art supplies so no other surface or space is needed. Finally, because of the number of clients working in the studios at any one time, in order for the team’s system to truly have an effect they would ideally be able to make more than one system for the artists to use.

Table 1: Customer Requirements and Weights

Customer Requirement	Weight
Adjustable configuration	45
Durable	40
Easily stored	30
Comfortable for daily use	25
Easy to assemble and disassemble	25
Safe to use	25
Capable of holding art supplies	20
Accommodate different size templates	15
Able to be duplicated	15
Accommodate different types of templates	10

2.2 Engineering Requirements

Based on the above customer requirements, the team came up with sixteen engineering requirements that further define the team’s future system. The engineering requirements were defined by a target value and an acceptable tolerance range when applicable.

First, in order to support the customer’s desire to have an adjustable configuration, the system must have a work surface capable of pivoting between 0 and 60 degrees from vertical. It must also be adjustable for heights between .8 and 1.5 m, and have a base less than 1 m wide. The team is aiming for a base width of .8 m. Second, in order to be considered durable, the system must have a material lifespan of more than 1000 uses, have at least four points of contact with the ground, and must not break if pushed over in its usable configuration.

In order to be easily stored in the limited space of the studio, the system must be contained within a volume of at most 1 m, and the team is aiming for a volume of .75 m. It must also be collapsible for simple storage, out of the way of the clients. In order for the system to be simple for one person to assemble and disassemble, it must not require more than five steps for use and must weigh between 10 and 40 lbs, with a goal weight of 30 lbs. In order to be safe for the clients to use, the system must not have any

exposed pinch points, as many points of contact with the ground as possible, and all edges should be rounded with a radius of at least .2 mm.

If the system is capable of holding art supplies, all components that come in contact with the supplies must be able to be washed by hand, for the convenience of the workers. Also, in order to make more than one system for the foundation, the total cost of one unit cannot exceed half of the team's budget, or \$750. Finally, because the Hozhoni Foundation uses a wide variety of templates, the system must accommodate templates from .25 to 1 m wide, and up to 15 lbs. These more detailed requirements helped the team analyze the feasibility of their designs during the brainstorming sessions.

2.3 Testing Procedures

It is critical that the team confirm that their engineering requirements have been met in order to confirm that they have met the customer requirements. The team developed several plans for testing different aspects of the prototypes and final design of the system. These testing procedures are numbered below and each necessary testing procedure is linked to its appropriate engineering requirement in the House of Quality below.

1. Measurement - One of the most simple ways to confirm data is through measurement. The team will measure different aspects of their physical design, using tape measures, calipers, scales, and other measuring devices. This test is necessary to ensure that the physical product matches the original system design and that all relevant engineering requirements fall within their tolerance range.
2. Motion Tests - The team will manipulate every moving part in the system to every possible position and set the system up in every possible configuration. By performing this test the team is making sure that the system operates as intended at every configuration. The test will be performed by each team member manipulating the system individually to make sure it can be operated by people of different strengths and abilities. Team members will record and movements that they find challenging so that they can be addressed and fixed in future prototypes.
3. Repetition Tests - The team will set up and collapse the design at least 100 times to ensure that they system can withstand repeated use. Each team member will perform the test at least ten times.
4. Carry Test - The smallest member of the team will attempt to carry the collapsed system 100 feet, to simulate the system being carried by one of the workers at the Hozhoni Foundation.
5. Spill Test - In order to simulate the spilling of paint and other mediums on the system, the team will splash water on the system to ensure that there is no lasting damage to the material during spills.
6. Template Tests - The team will take the system to the Hozhoni Foundation and set it up with their largest available canvases and all of the different material they use to ensure that the system is stable with many different templates.
7. Push Test - The system will be pushed over in both its collapsed form and the assembled configuration at least once to ensure it will not break when it falls.

2.4 Design Links

The team has created a final design, described fully in Section 5, that they feel meets all of the above Engineering Requirements. The numbered design links below explain how aspects of the design meet each engineering requirement, and they are correlated to each requirement in the House of Quality in Section 2.5.

1. In order to be able to adjust the angle of the easel back the team designed a ratcheting system similar to something you might see on the back of a lawn chair. Two bars with a sawtooth design will hook onto an aluminum bar below the desk, allowing the template to be placed at a range of

angles. The easel back will be hinged at the connection with the desk in order to allow for easy movement between angles.

2. All of the corners on the desk portion of the system will be rounded with a fillet of .5 in in order to keep them from being potentially dangerous.
3. The team implemented several characteristics into the design so that the system will be able to collapse. The easel back will be able to lay horizontal with the desktop through the use of hinges. The desk legs will be able to fold up under the desk using a system similar to that seen on a plastic folding table. These two movements will collapse the system into something that can be carried by one person. This will also reduce the volume of the system for storage to be within the team's tolerance range.
4. The team took great care in choosing the material that the system would be made with. The collapsible legs will be made with steel, in order to support the weight of the desk and to withstand many uses. The sawtooth ratcheting system on the back of the easel will be made with aluminum in order to keep the easel lightweight and easy to adjust, and the desk and easel will be made with plywood project panels, treated with waterproof stain. These material selections allow for the system to be lightweight for transport, easily cleaned, and durable during use. They will also allow the system to continue operating well past the team's target of 1000 uses. Finally, the team chose these materials because they are easy to find and therefore relatively cheap. Using these materials will allow the team to potentially make more than one system.
5. In order to require five or less steps for use, the team designed the collapsible legs so each set of legs on either side of the desk are connected. Using this design, the legs can be extended or shortened in one step. They also chose to use the sawtooth design for the ratcheting system because it allows the angle of the back to be adjusted using one hand, in a single step.
6. To minimize pinch points on the work surface of the desk, the team decided that they will mill a step into the back of the desk surface so that the easel back will not sit directly on the surface of the desk, but lower into the material. This allows for the pinch points to be off of the level desk surface, and therefore harder to encounter.
7. The easel back will be equipped with a detachable peg bar that will serve as a resting place for the art templates. This bar will use a series of pegs to connect to the back of the easel to distribute the weight of the templates, as well as provide a large peg surface area that can support any template in the tolerance range that the team specified. The peg bar will be detachable in order to keep the surface of the easel flat for storage.
8. The legs that the team plans on implementing give the system four points of contact with the ground through the use of steel bars connected to 'U' shaped feet. The legs will be able to be extended or shortened in order to adjust for a sitting or standing configuration, as well as people of different heights. They will be positioned on the edges of the desk in order to give the maximum amount of clearance between them to accommodate wheelchairs of different widths.

2.5 House of Quality

The House of Quality is a tool that can be used to visualize the correlation between requirements from the stakeholders and engineering requirements. The House of Quality includes the customer requirements; engineering requirements, appropriate tolerances, as decided by the team members, testing links, and design links. This can be seen in Figure 1 below. The customer requirements were sent to the Hozhoni Foundation for approval. The signed approval from the stakeholder can be found in Appendix A.

Customer Requirement	Weight	Engineering Requirement	Work surface adjustable angle	Rounded Corners	Collapsible	Must be contained within set volume	Movable by one person	Can be cleaned by hand	Requires less than 5 steps for use	No exposed pinch points	Can accommodate different template widths	Can accommodate different template weights	Will not break if pushed over	Many points of contact with ground	Long material lifespan	Have a minimum leg width	Adjustable template height	Low cost to build	
Adjustable configuration	45	9																	
Durable	40				3					1			9	9	9	1	1	1	
Easily stored	30	1		9	9	3				1						1	1		
Comfortable for daily use	25	9	3			1	1	3	3	1	1					3	3		
Easy to assemble and disassemble	25			3	1	9		9	3										
Safe to use	25	9							9	1	1		9						
Capable of holding art supplies	20						9												
Accommodate different size templates	15	3								9	9								
Able to be duplicated	15																		9
Accommodate different types of templates	10	3								9	9								
Target(s), with Tolerance(s)			0-90 deg	r> .2 mm		0-1 m ³ -- .75m ³	10-40 lbs -- 30 lb				.25 m to 1 m	up to 15 lbs		4 pts	> 1000 uses	< 1 m -- .8 m	.8-1.5 m	<\$750	
[add or remove T/T rows, as necessary]																			
Testing Procedure (TP#)			2	1	2	1	1,4	5	2	2	1,6	1,6	7	1	3,5,7	1	1,6		
Design Link (DL#)			1,4	2	3	3	3,4	4	5	6	7	7	4	8	4	8	8	4	

Figure 1: House of Quality

3 Existing Designs

In order to design a solution, which satisfies the needs of Hozhoni art program participants, it is necessary to perform benchmarking and state-of-the-art design research. The existing system at the Hozhoni art program was closely examined, and existing technology relevant to the customer needs was researched.

3.1 Design Research

The benchmarking process included visits to the Hozhoni art studio. The team has visited the Hozhoni studio several times in order to better understand the existing system. During visits to Hozhoni, employees showed the team the facilities including the art rooms, storage closet, and gallery while explaining the organization and current devices in use. Issues confronting Hozhoni artists and design limitations were discussed with employees. Hozhoni artists showed off their creations and added some input as well. From site visits to Hozhoni, the team will be able to better understand some of the needs and limitations of the art program participants.

Furthermore, background research was conducted on existing designs relevant to the customer requirements. Research was conducted through online searches and product browsing. Publications explaining some of the benefits of art therapy were helpful to understand the potential this project has at improving quality of life. However, most background research involved current technology relevant to the Hozhoni artist’s needs, specifically assistive devices. Background research was focused on two areas, general assistive technology and art related assistive technology. The results of the background research into existing designs is explained in the following section.

3.2 System Level

Background research was divided into two areas of focus, general assistive technology and art assistive technology. Assistive technology can be defined as systems or devices providing assistive, adaptive, or rehabilitative support for individuals with special needs or disabilities. Assistive technology covers an extremely wide variety of needs and applications. Background research produced three general assistive technologies and three art related assistive technologies, which were most relevant to the needs of Hozhoni artists. These existing systems and devices provide insight as to how others have solved similar problems. The concepts portrayed by the designs explained in the following section are relevant to the needs and limitations of Hozhoni artists.

3.2.1 Populas Wheel Chair Accessible Desk

There are many different shapes and sizes of wheel chair accessible desks. This particular design, as seen in Figure 2, is a rectangular desk with a slight cut out in the edge to allow the user to comfortably work on the surface. A knob on the legs of the desk allows for the height to be adjusted as well, which is a largely weighted requirement in this project [3].



Figure 2: Wheel Chair Accessible Desk

3.2.2 ErgoRest Arm Support

This device is easily clamped onto the side of a table or desk providing the user with arm, shoulder, and neck support. It is comfortable and does not restrict any motion of the user. This device could be important to this project in that it can show the team how to provide comfort and support to the client without restricting their motions so that they can still work [4].

3.2.3 Ergo Q330 Notebook Stand

This notebook stand allows the user to adjust the angle at which their laptop is facing them. This product is important to this project because the easel needs to have an adjustable angle too. The team can learn from how this stand works and implement it into the design of the easel [4].

3.2.4 Da Vinci Multi Media Easel

This device provides a platform for painters and drawers alike. The easel was chosen since it incorporates several of the customer requirements presented in section 2.1. First off, the easel is adjustable. The frame, which holds the canvas, can be positioned vertically and horizontally, and anywhere in between. This easel's adjustability is reflective of the most heavily weighted customer requirement for this project, since the device must be wheelchair accessible. When not in use, the easel can be folded and stored flat, another important characteristic given the limited space in the Hozhoni art studio. The easel features a center mast stabilizer and rubberized grips on the top and bottom canvas holders to allow for different sizes and types of media. Finally the easel has a built-in utility shelf for storing supplies. This easel is much better suited for use at Hozhoni than the current system, and its characteristics will be considered during the design selection process [5].

3.2.5 Digital Wheel Art

Digital Wheel Art is a system, which allows wheelchair bound individuals to create visual art, in real time, using the movement of their chairs. The system can be implemented with either a powered or manual wheelchair. A sensor is placed on the user's chair, which transmits a signal to a Nintendo Wii remote. The remote then communicates with drawing software that projects the user's movements as colored lines onto a screen for real time viewing. This technology is relevant to the customer requirements in that it provides an alternative method for people with disabilities to express themselves [6].

3.2.6 Mabef Workstation Easel

This device provides a workstation for artists in wheelchairs as well as artists who prefer to paint sitting down. The workstation has ample space down below and a U-shaped design to comfortably accommodate a wheelchair. The easel can be positioned vertically or horizontally, and can even lean forward up to 10 degrees. Vertical and horizontal drawers are featured on the sides to store art supplies, and shelves, which swivel outwards further increase workspace area. In accordance with the customer requirements this device is adjustable for individual needs and features multiple storage compartments [7].

4 Designs Considered

For the designs considered, the team decided upon five art assistive devices best suitable for the clients. As stated earlier, it is important that the product be suitable for any canvas size, easy to assemble and disassemble, take up minimum storage space, and comfortable for the clients. All the following designs can be seen in Appendix B.

4.1 Folding Easel

The first design appears as a simple 4-legged, stand-alone easel. There is a wide board that holds the canvas in place on top of 4 sturdy legs of an undefined material, and a plank attached to the back legs to add support to the easel. The left and right edges of the board can be folded into the center of the board to save space and be adjustable for the size of the canvas. The front and back legs can be folded vertically as well to help with storage space. Lastly, the board is supported by a dowel attached to the back legs, and the dowel can be adjusted to any angle.

4.2 Round-About Easel

This design is a half moon shaped desk with a wooden frame standing up from the desk's surface. The shape of the desk is created that way so that it is wheelchair accessible. The purpose of the desk is to have some room for art mediums, or to create some room for clients who lay down their heads and arms while they create their art. The wooden frame is the structure where the canvas is placed. The roundabout easel has 3 foldable legs that help for storage space, and the wooden frame can be adjusted to support the size of the canvas.

4.3 Sawhorse Easel

The sawhorse easel is an easel created from two individual parts. For the legs are an adjustable sawhorse stand, with the legs placed on the side so that it is wheelchair accessible. Depending on the height of the client or the canvas, the sawhorse legs can move from a small angle to a larger angle to change the height. The easel frame was inspired from the Russian dolls concept, where the frame is consisted of different beam sizes so that it can expand or contract to the size of the canvas. This concept allows the frame to be stacked inside of each other to decrease space.

4.4 Full Moon Easel

This design is a full circle easel that lays parallel to the floor, much like a table. However this stand has an opening to allow clients of all sizes to fit, and empty space inside of the stand for clients to work in. Like the other designs, it is also wheelchair accessible. This stand can be folded in half for storage, and is lightweight for easy removal by the workers or clients. One section of the stand will have an area to hold a canvas at an angle. This stand can be used for holding paints and canvases, and multiple clients can use this stand since they can create art inside or outside of it. The four legs that hold the stand fold up to help with storage.

4.5 Skeleton Easel

The skeleton easel will not have many components to it. It consists of four legs with rollers to help mobility and a stand to connect the legs with the easel frame. The easel frame consists of two rectangular

aluminum bars in the shape of a cross, and each bar has holes in it. These holes are points where small blacks can lock into place to hold the canvas up, and the different lengths of each hole allows larger canvases to be placed upon it. At the bottom of the vertical bar is an extended plank to hold up the easel. This plank is extended so that paints and paintbrushes can be within reach. This design is lightweight, easy to transport, and sturdy.

5 Designs Selected

5.1 Rationale for Design Selected

Using the team’s designs considered, the following decision matrix was created. The values given for each design is based on a scale from 1 to 10, 1 being the worst aspect and 10 being the best. However with the requirement of cost, the lower the number, the lower the cost the better it is because less materials are needed.

Table 2: Decision Matrix

	Weighting (%)	Folding Easel	Roundabout Easel	Sawhorse Easel	Full Moon Easel
Durability	20	7	8	6	8
Stability	15	6	6	8	8
Safety	15	8	9	9	8
Ease Of Use	15	10	9	6	4
Cost	10	6	7	3	2
Versatility	10	4	7	5	3
Storage	15	5	7	6	3
Total	100	6.45	7.55	6.3	5.5

Based upon the results of our decision matrix, the Round-About Easel is the optimal design. It has the greatest ability to suit all of our clients and is adjustable for physical parameters such as height, and it is wheelchair accessible. However it has been modified from the original design to fit the criteria where it lacked compared to the other designs. Our end goal is to make the product durable, easy to use, and lightweight enough so only one person can tinker with it.

The first modification is the shape of the structure. The easel will now have four hollow legs to increase balance and storage space. The outer legs are hollow, with a smaller diameter leg inside that helps the legs extend. The legs will adjust the height from 2.5 feet to 4 feet to suit all clients who both stand and sit when painting. Aside from the legs, the tabletop will have a section carved out to hold art mediums within easier reach. This way paints can be more organized and the empty space can be used by other artists.

The second biggest modification created is on the stand where the canvas is placed. The stand can now be adjusted to a wide variety of angles and able to lay flat for clients who prefer to paint while laying their head down. The adjustable angle allows the artists to be comfortable and help with their posture. In order for the stand to lay flush with the tabletop, the back section is designed to be thinner than the front where the artist is. The team decided upon this modification because a few of the clients preferred to paint or draw horizontally as opposed to an angle. These modifications were considered after consulting with professional physical and occupational therapists. More detailed notes can be found in Appendix C.

5.2 Design Description

The final design is shown below in Figure 3 through Figure 4 with parts labeled in the adjacent table on Figure 4. These sublevel system parts, details, and materials are discussed and described in further detail in subsections 5.2.1-5.2.6 below. This drawing table design has been drafted to accommodate different working heights, different backboard positions, and collapsibility for easy storage. The process diagrams for these adjustments are included in subsections 5.2.7. Complete material specifications, costs, and anticipated suppliers have been listed in the complete Bill of Materials included in Appendix C.

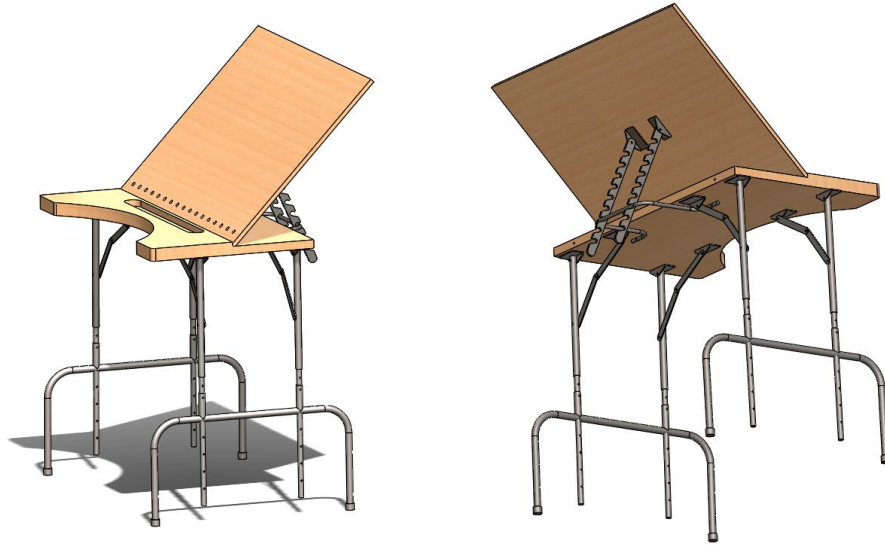

Figure 3: Left – Easel front view. Right – Easel back and below view

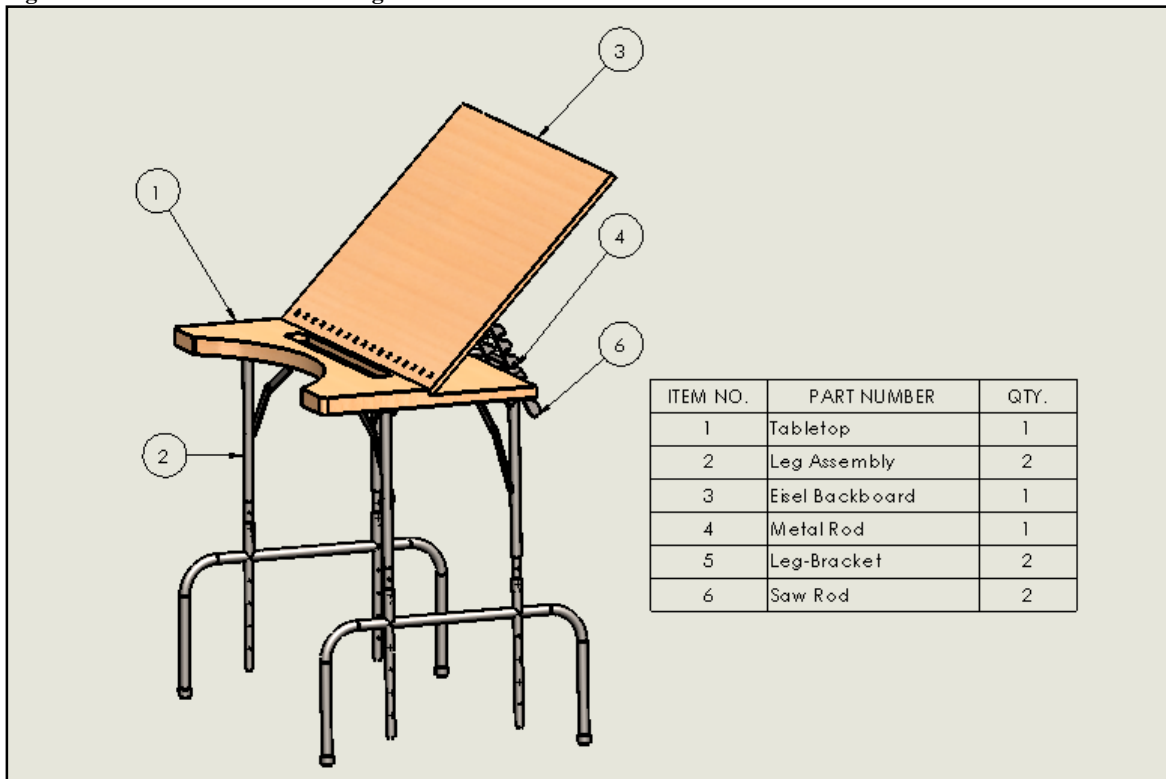

Figure 4: Complete Easel Design with labeled sublevel system parts (leg bracket not shown)

5.2.1 Table Top (1)

The tabletop provides a horizontal surface for the comfort and convenience of the clients. A figure of the tabletop is included below. For full drawing, with dimension, refer to Appendix C.

The tabletop is made of stained and polished woods for aesthetics, durability, and easy cleanup. The elongated back allows for the support of the canvas when folded for storage and the attachment of the metal rod for propping. A circular cut out has been made for improved ergonomics and client comfort. The slot cut allows for the placement of supplies and prevents them from rolling off the table during a work session.

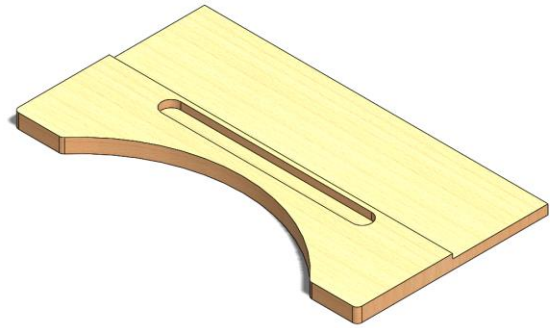

Figure 5: Tabletop

5.2.2 Leg Assembly (2)

The leg assembly is a modified commercial tabletop leg system. The legs fold flush to the bottom of the table as can be seen in the process diagrams in subsection 5.2.7. The commercial legs have been modified to allow for adjustment in table height. This will be accomplished by sawing the hollow metal legs and welding a rod to the upper section. This rod will then have holes drilled to allow for a pin-system to change leg height and position. This should not interfere with wheelchair accessibility and will allow clients to stand and work if preferred. A diagram of the legs is included below.



Figure 6: Leg Assembly

5.2.3 Easel Backboard (3)

The easel backboard is a supportive structure for various canvas and drawing templates. This backboard can change degrees and positions ranging from 0-60 degrees incrementally. This movement is accomplished using a simple mechanical system with the metal rod support, leg bracket, and saw rod. The saw rod has various cut out positions for rest on the metal rod support allowing for the necessary degree implements. This has been done for the comfort and convenience of the clients as well as the ability to store the system when not in use. The Easel backboard will fold flush to the tabletop as shown in the process diagrams in subsections 5.2.7. Additionally circular cutouts have been made for the addition of a support piece to hold the templates in place. The Easel Backboard diagram is included below and engineering drawings are included in Appendix C.

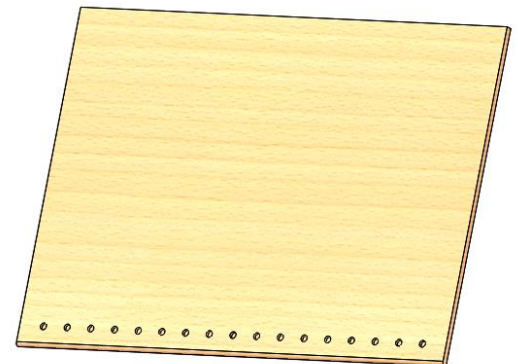

Figure 7: Easel Backboard

5.2.4 Metal Rod Support (4)

The metal rod support is screwed to the bottom of the tabletop and placed in a position such that it does not interfere with the folding legs. The piece will be made out of an aluminum rod. This support aids in the propping of the easel backboard, position shown below.

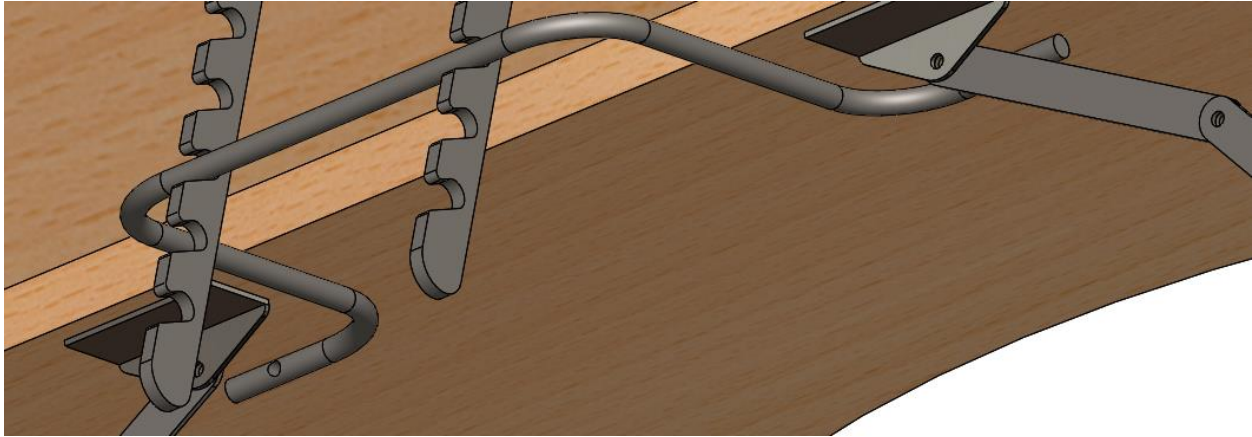

Figure 8: Metal Rod Support

5.2.5 Leg Bracket

The leg bracket allows for the attachment and swivel of the saw rod for the support of the easel backboard. This is a commercially available part

5.2.6 Saw Rod (5)

The saw rod is the primary component allowing for the modification and variability of the easel backboard angle. It uses mechanics similar to that of commercial lawn chairs with cut outs resting on the metal rod support as seen in the above Figure 8 in subsection 5.2.4. These will be made and cut from thick scrap aluminum or 3d printed for the necessary strength and support. A drawing of the saw rod has been included in Appendix C.

5.2.7 Processes Diagrams

The easel design has been drafted for easy storage, collapsibility, and adjustment. The primary mechanisms for the storage of the device are the lowering of the easel backboard to lie approximately flush with the tabletop and the collapsing of the legs. The light weight of the table and the simple mechanisms allow for the easy collapsing and deployment as shown in Figure 9 below.

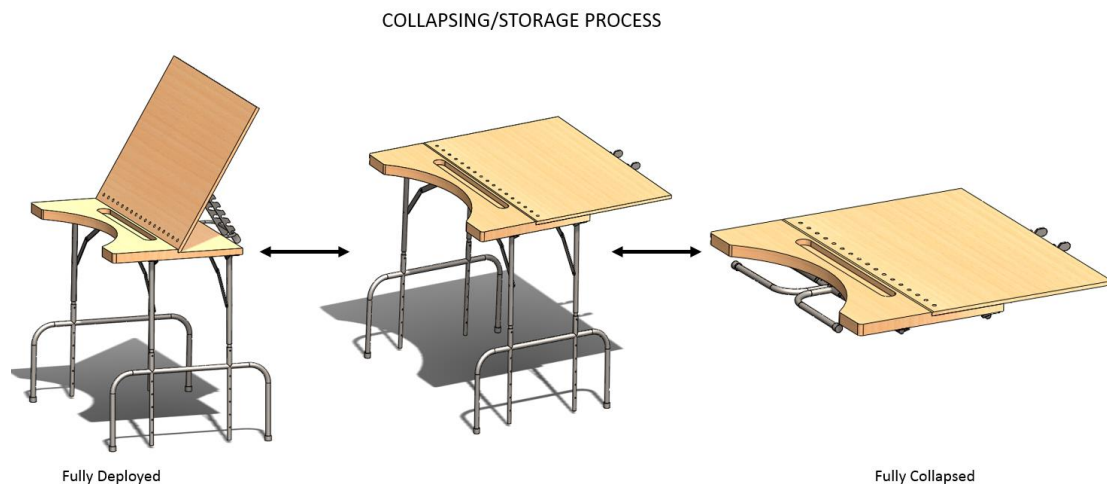

Figure 9: Storage and Deployment Process

The second important process to the adjustability of the easel system is the extension of the legs as shown in Figure 10 below.

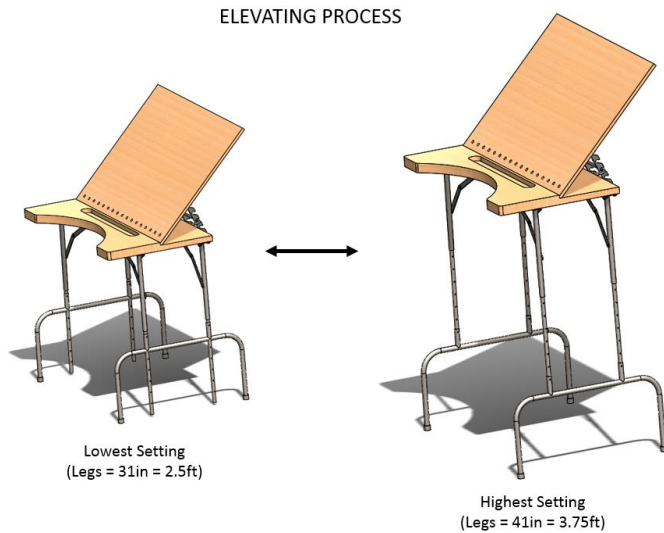

Figure 10: Elevating Process

6 Implementation

In order to successfully build and implement the proposed design, various stages of prototyping and testing are required. The prototyping and testing phases must be in accordance with the capstone class schedule and deliverables as outlined in the course syllabus. First, a basic model of the design was constructed using cardboard, tape, and other materials. This small-scale proof-of-concept model incorporates the design characteristics described in the previous section. The model will also serve as an alpha prototype, a crude version of what the final design will be. Based on the design description, the team produced a bill of materials needed to create a more detailed, full-scale beta prototype. Supplies will be purchased online or in person, and soliciting local shops for scrap material will also be considered. Team members' own personal materials and tools can be used in addition to those purchased. The team will work together to construct a beta prototype and will utilize the engineering machine shop on campus when needed.

Once a functional beta prototype has been developed, the testing process will begin. The team plans to implement the prototype at the Hozhoni Foundation over the course of a week in order to gauge the design's performance. Using feedback gathered during the initial week of testing, the system can be modified and improved upon in order to create a final version. After the final design is complete, a second phase of testing will commence. Again, the design will undergo several days of testing at the Hozhoni Foundation. Depending on the test results, last minute modifications will be made before the UGRADS presentation at the end of April. A Gantt Chart was created to outline the implementation process as well as the required class deadlines and deliverables. The Gantt Chart can be seen below in Figure 11.

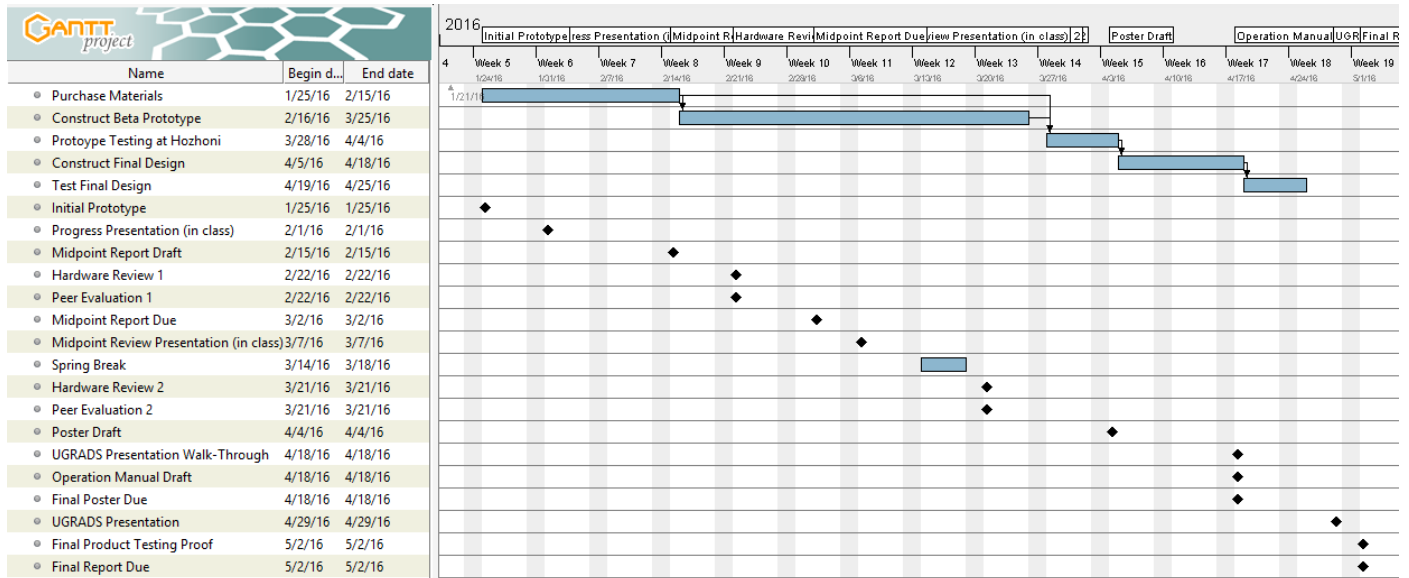

Figure 11: Schedule of Implementation

After creating the Solid Works model for the final selected design, the team was able to make a complete bill of materials for the chosen design, which can be seen in Table 3 below. The total cost for the beta prototype will be \$210. This price should not change too much for the final product, so the team will be well within the given budget of \$1,500.

Table 3: Bill of Materials

Item No.	Description	Material	Quantity	Price (Total)	Comments
1	Folding Legs	Steel	2	50	Purchase from Amazon
2	Table Top	Wood Board	1	50	1.5" thick, from Home Depot
3	Saw tooth Support	Aluminum	-	20	Scrap from the machine shop
4	Brackets/Bolts/Screws	-	-	50	Home Depot
5	Leg Extension	Steel	4	35	Home Depot
6	Rod Support	Aluminum	1	5	Home Depot

References

- [1] Hozhoni.com, "Hozhoni Foundation - Dignity Through Opportunity", 2015. [Online]. Available: <http://www.hozhoni.com/>. [Accessed: 16- Dec- 2015].
- [2] Hozhoniartists.org, "Hozhoni Artists & Art Studio | A non-profit visual arts program where artists with developmental disabilities create, exhibit, sell and collaborate with other artistsHozhoni Art Studio", 2015. [Online]. Available: <http://hozhoniartists.org/>. [Accessed: 16- Dec- 2015].
- [3] schooloutfitters.com, "Knob-Adjusted Wheelchair Accessible School Desk", 2015. [Online]. Available: <https://www.schooloutfitters.com/catalog/>. [Accessed: 17-Dec-2015].
- [4] Alimed.com, "ErgoRest® Extended Height Articulating Arm Support", 2015. [Online]. Available: <http://www.alimed.com/>. [Accessed: 17-Dec-2015].
- [5] jerrysartarama.com, "Da Vinci Multimedia Easel", 2015. [Online]. Available: <http://www.jerrysartarama.com/discount-art-supplies/easels/studio-easels/da-vinci-multimedia-easel.htm>. [Accessed: 17-Dec-2015].
- [6] Chung, Younghyun, "Digital Wheel Art", 2008. [Online]. Available: <http://risknfun.com/project/digitalwheelart/>. [Accessed: 17-Dec-2015].
- [7] dickblick.com, "Mabef Painting Workstation Easel M-30", 2015. [Online]. Available: <http://www.dickblick.com/products/mabef-painting-workstation-easel-m-30/#photos>. [Accessed: 17-Dec-2015].

Appendix A

Stakeholder approval of the customer requirements.

Customer Requirements:

- Comfortable for daily use
- Easily stored
- Easy to assemble and disassemble
- Accommodate different size templates
- Accommodate different types of templates
- Capable of holding art supplies
- Durable
- Adjustable configuration
- Able to be duplicated
- Safe to use

Engineering Requirements:

- Work Surface angle adjustable up to 90 degrees
- Rounded Corners
- Collapsible
- Must be contained within max volume of 1 m³
- Movable by one person
- Can be cleaned by hand
- Requires less than 5 steps for use
- No exposed pinch points
- Can accommodate different template widths
- Can accommodate different template weights
- Can be pushed over and survive
- As many points of contact with the ground as possible
- Long material lifespan
- Minimum leg width of standard power chair + 2 in per side
- Adjustable template height from 2.5 to 4.5 feet
- Cost to build less than half total budget

I agree with the above stated Customer and Engineering Requirements.

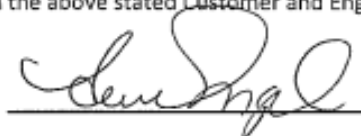
 12-9-15

Appendix B

All of the designs considered that were included in Section 4 of the report.

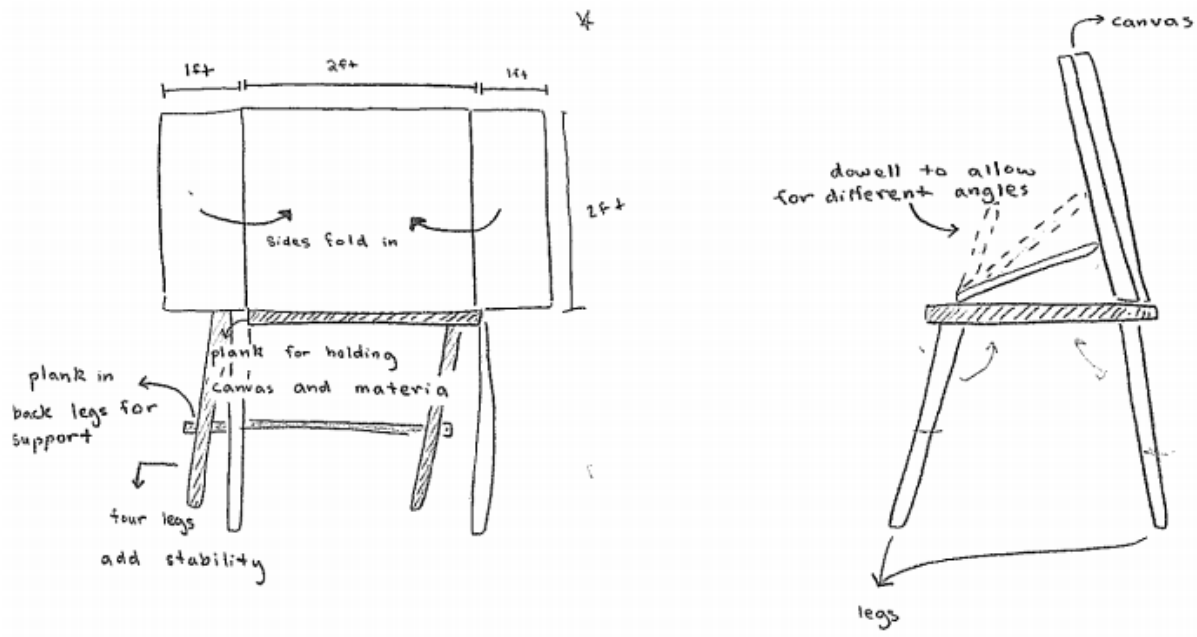

Figure B.1: Folding Easel

Round-about Easel

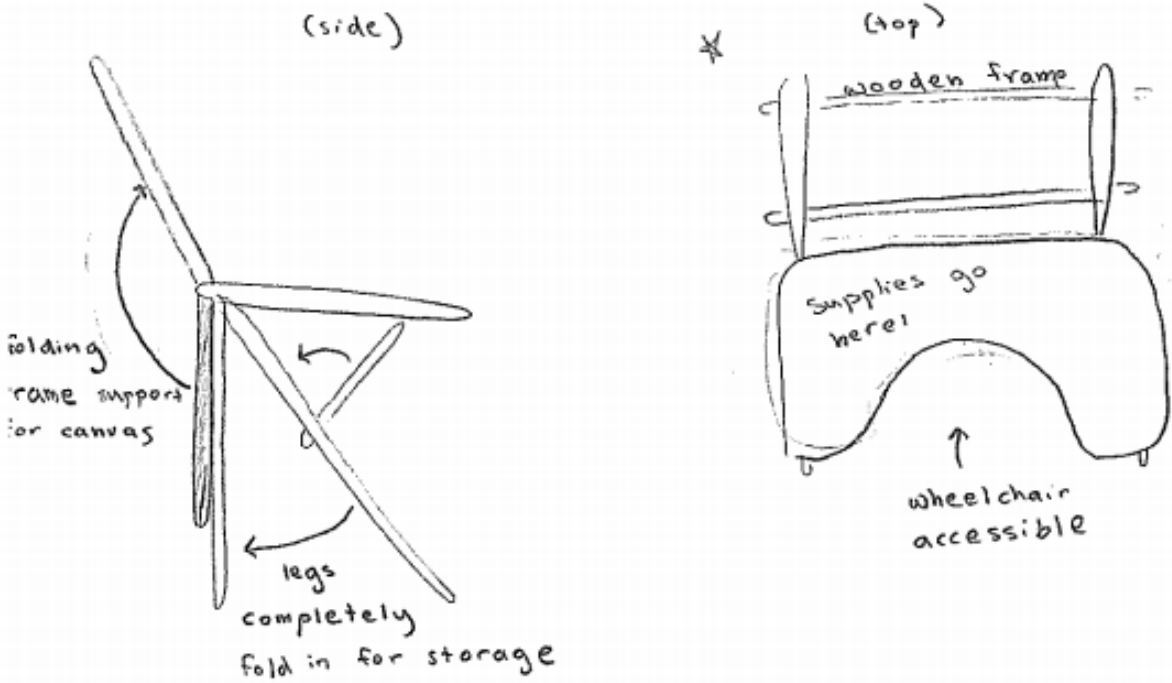
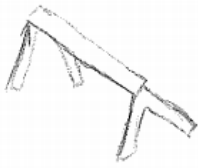
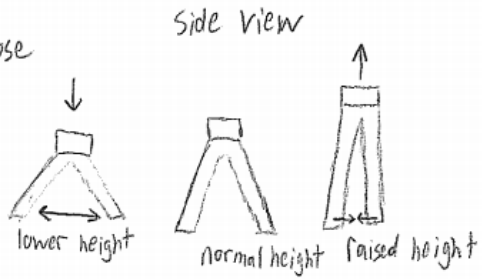

Figure B.2: Roundabout Easel

Sawhorse Concept for base



- legs can open or close to adjust height
- legs on sides so wheelchair can fit in between



* Easel Frame

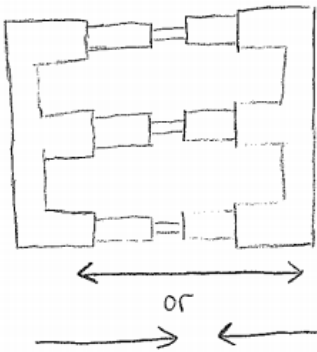

- expand or contract to accommodate different size canvases
- concentric cylinders/beams of different areas
 - can be stacked inside each other

Figure B.3: Sawhorse Easel

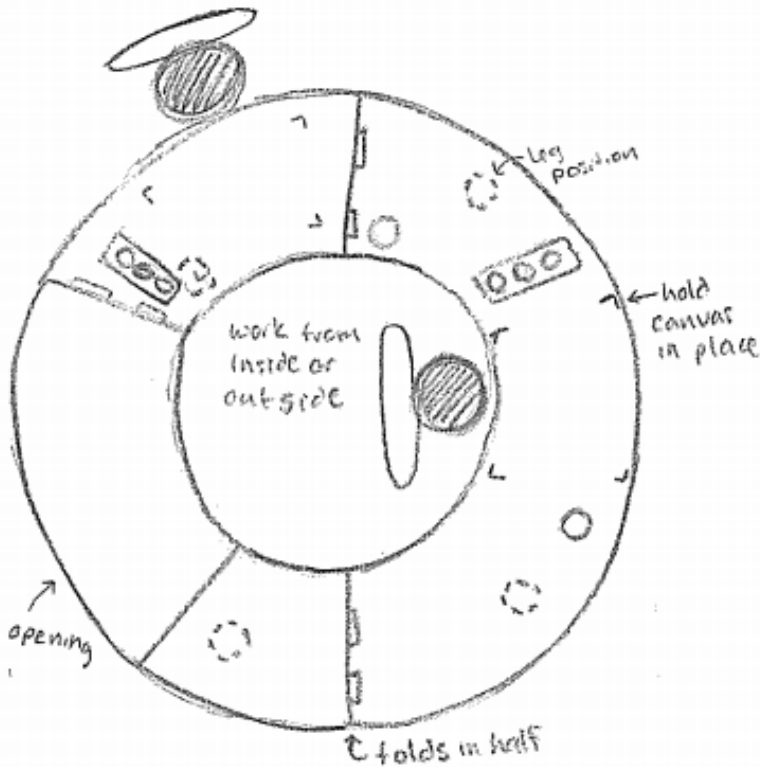

Figure B.4: Full Moon Easel

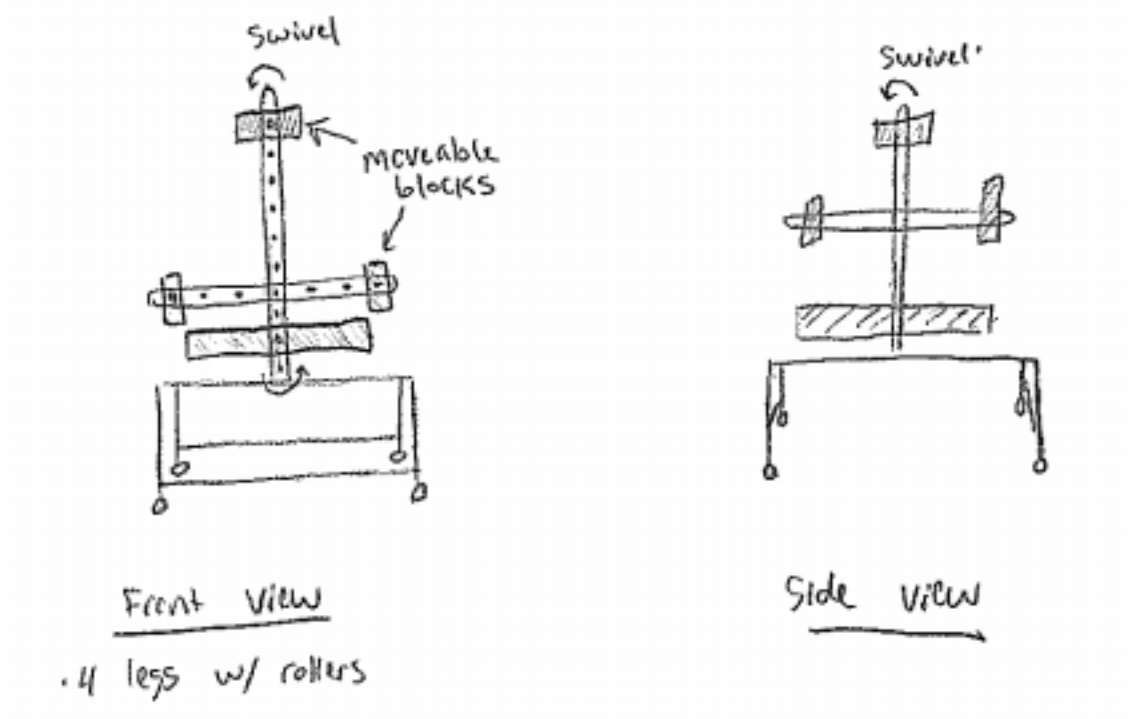
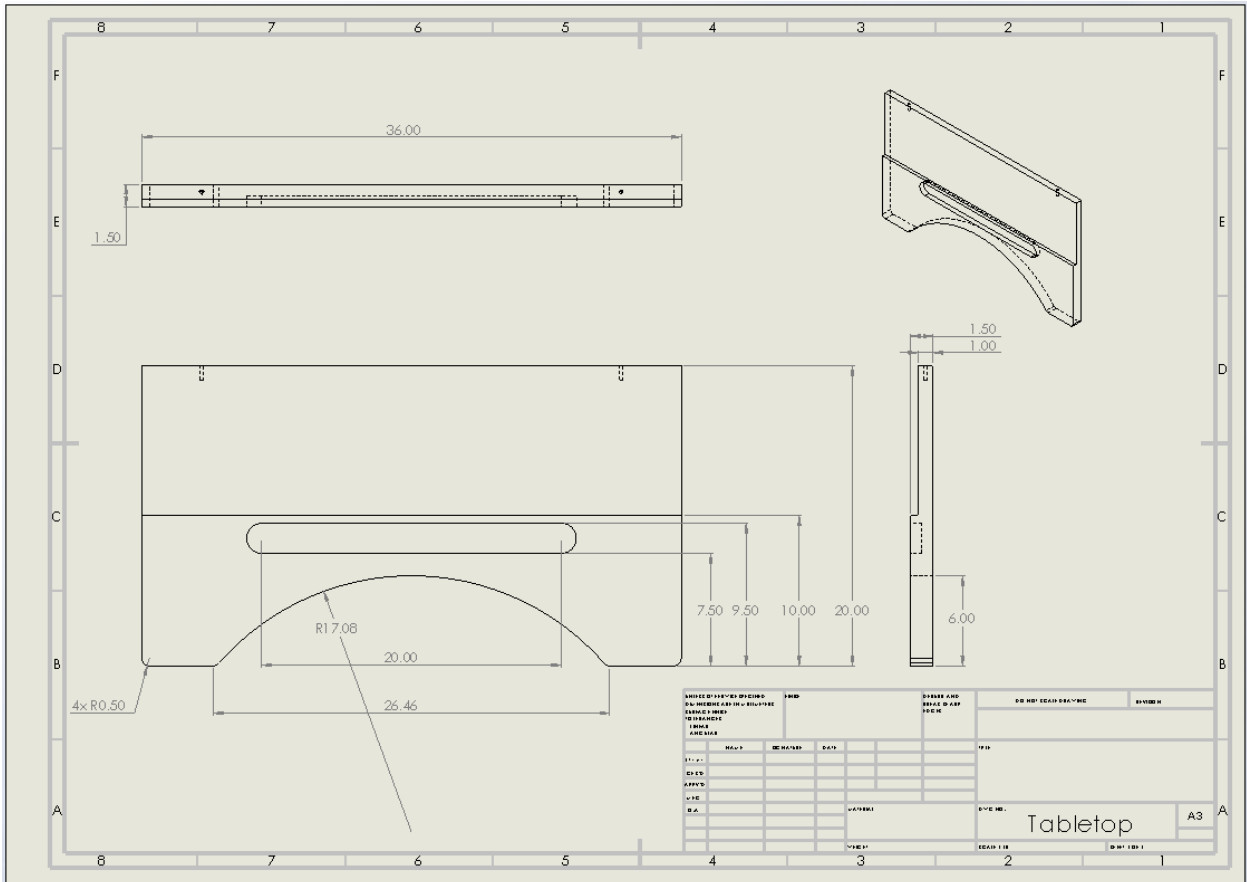

Figure B.5: Skeleton Easel

Appendix C

Solid Works measurements of the final selected design.



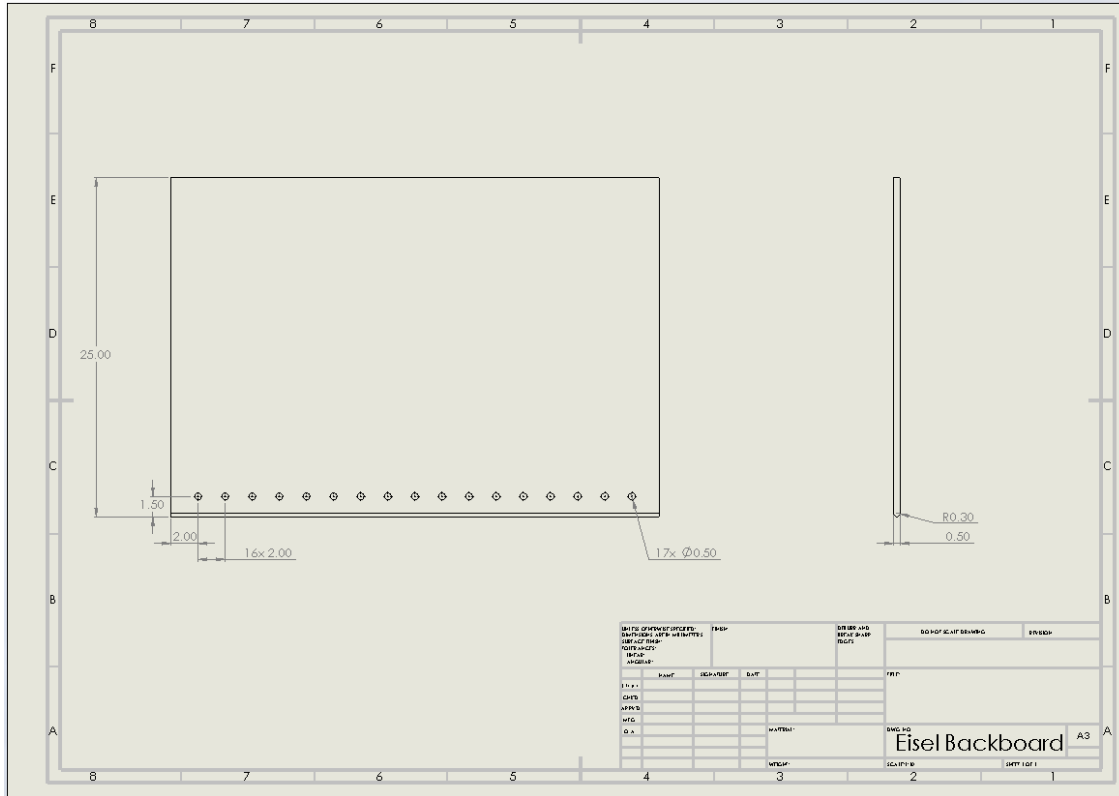

Figure C.2: Eisel Backboard Drawing

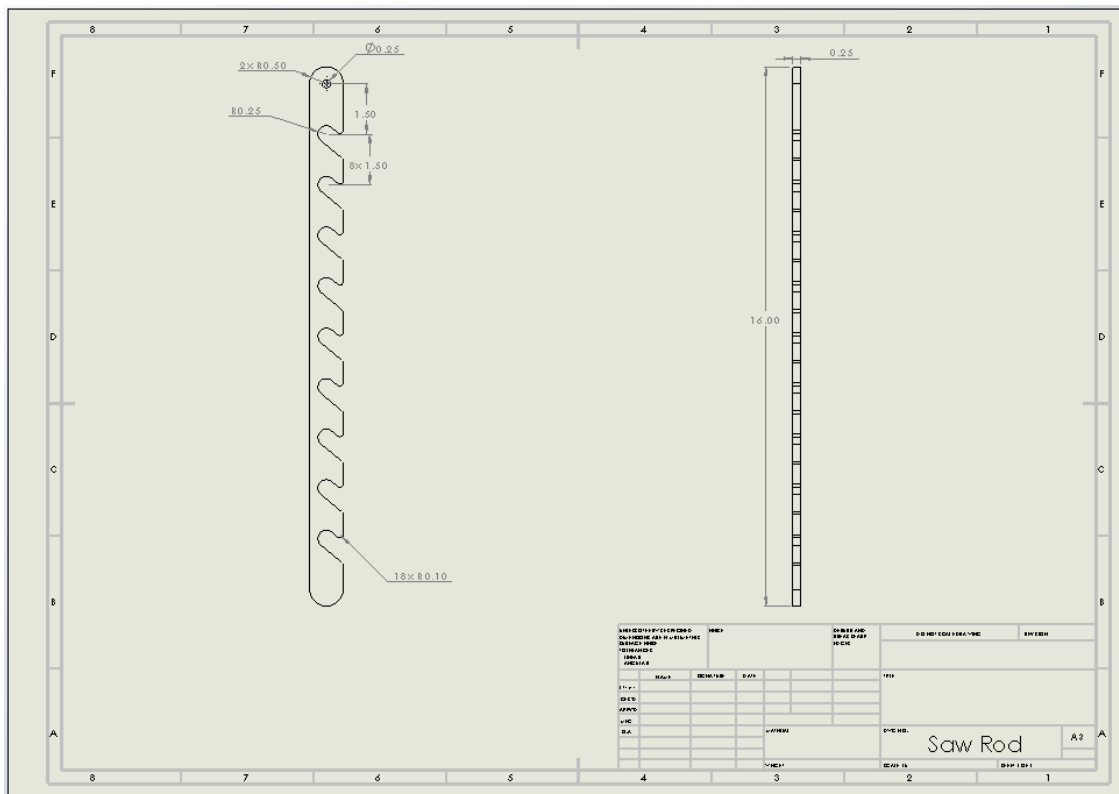

Figure C.3: Saw tooth Drawing